

Easy Lock

RFID
MIFARE

PROXIMITY LOCK RFID MIFARE 13,56 KHZ

Mod. DMI13PG/B/A

Bolt Length - 13 mm

Mod. DMI18PG/B/A

Bolt Length - 18 mm

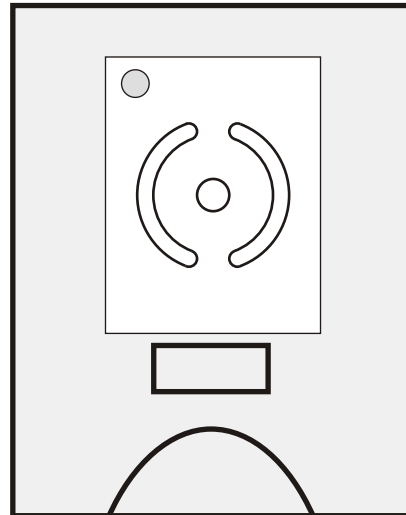

**READ THE INSTRUCTIONS CAREFULLY
BEFORE USE AND KEEP THEM FOR
FUTURE REFERENCE**

USER'S GUIDE

PAGE 2

MAINTENANCE

PAGE 4

INSTALLATION GUIDE

PAGE 8

USER'S GUIDE

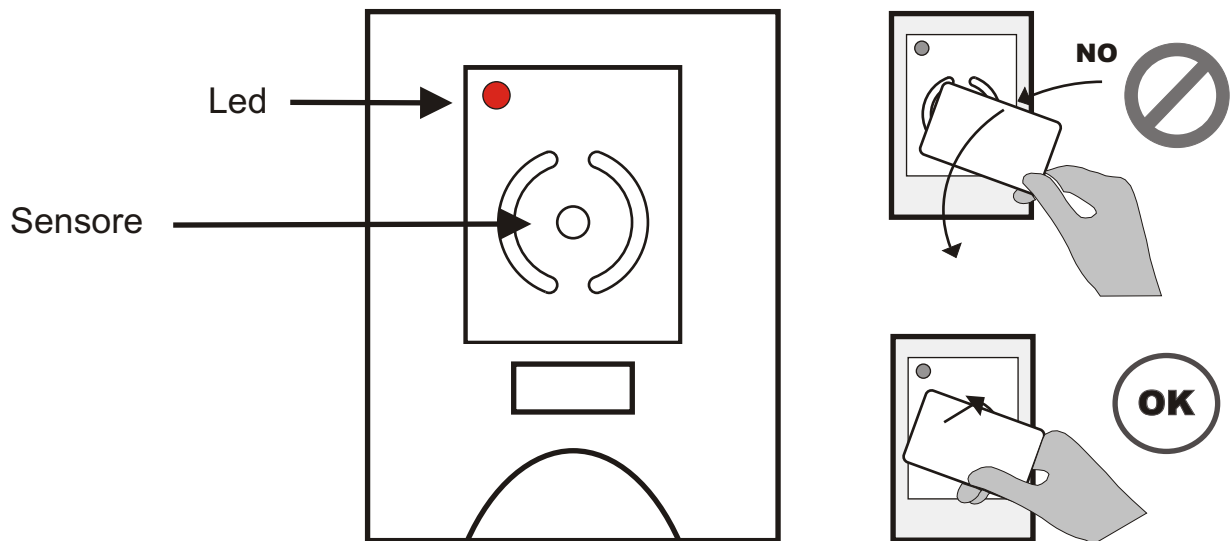

SHARED USE :

The lock closes with any compatible TAG (Card or Wristband) and it will open only with the same TAG used to close



CLOSING

Lean the TAG (Card or Wristband) to the centre of the sensor.

The LED will shortly flash 1 time every 2 seconds to indicate that the lock is closed



OPENING

Lean the TAG (Card or Wristband) used to close to the centre of the sensor.

When the lock is open the LED stays OFF.



OPENING WITH PASSEPARTOUT CARD

Lean the PASSEPARTOUT Card to the centre of the sensor



PERSONAL USE

It is possible program the lock so that it works with a specific personal TAG (Card or Wristband).

With the lock “open” lean the special READ FIXED card to the center of the sensor and remove the card only when the the LED turns “ON”.

Within 5 seconds (before the LED turns “OFF”) lean the personal compatible TAG (Card or Wristband) and remove the card only when the LED stays “ON” after has issued short flashes.

After this procedure the lock will work only with the personal TAG (Card or Wristband) programmed.

Note : with the personal use mode when the lock is closed the led does not flashes

To return in the mode Shared Use :

With the lock “open” lean the special FIXED ERASED card to the centre of the sensor and remove the card when the LED turns “ON”.

After this procedure the lock closes with any compatible TAG (Card or Wristband) and it will open only with the same TAG used to close



TIMER SETTING

By inserting the timer, the lock will open after an established time everytime it is closed.

To set the timer please follow the instruction below :

With the lock “open” lean the special TIMER with the value of the hours that you wish to program to the center of the sensor and remove the card when the LED turns “ON”.

When the lock is closed the LED will shortly flash 2 time every 2 seconds to indicate that the lock is closed with the Timer “ON”.

For disconnecting the Timer proceed as above and use the TIMER card with value “0”.

READ CAREFULLY

FEW INSTRUCTIONS AND SOME SUGGESTIONS TO KEEP EFFICIENT THE LOCKS



CLEANING

Clean the lock exclusively with a damp cloth.
Avoid soap, solvents, alcohol etc.

AVOID TO MAKE ENTER THE WATER IN THE LOCK



If the water gets inside the lock in addition to discharge the batteries can permanently damage the lock



BATTERIES (see page 5)

When the batteries have not enough power to close the lock the led red turn ON and stays ON until the complete discharge of the batteries. (approximately 10 days)

Replace them only with **ALKALINE** batteries (AAA) observing the right polarities.
Do not use rechargeable batteries



*When you noted that the led is ON replace as soon as possible the batteries.
If the discharged batteries remain in the lock they could release some acid substances which damage the contacts*



PASSEPARTOUT CARD

When you have the need to change the passepartout card verify that the new passepartout card works correctly after the changing



To avoid confusion is advisable to program the same PASSEPARTOUT card for all the locks installed.



OBSTACLE (see page 6)

If during the closing (or the opening) the led flashes quickly and continuously without stays "ON" this means that the bolt has met an obstacle and it unable to close (or open).



In this case remove the obstacle or verify that the door is well-aligned and adjust, if it necessary, the hinges of the door or the stop-bolt

ATTENTION

PLEASE NOTE THAT THE NON-OBSERVANCE OF THE RULES IN THIS GUIDE FOR A CORRECT MAINTENANCE WILL AUTOMATICALLY VOID EVERY KIND OF WARRANTY OF THE PRODUCT.

REPLACING THE BATTERIES

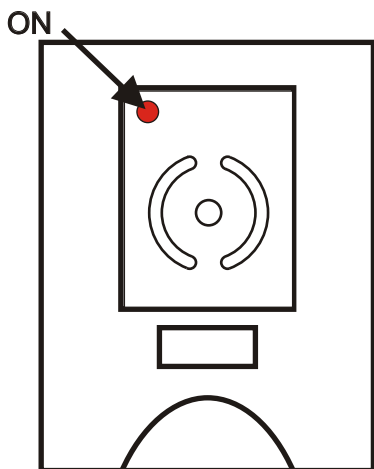

THE LOCK DOES NOT WORK AND THE RED LED
IS "ON"
or
THE LOCK IS COMPLETELY INACTIVE



BATTERIES DISCHARGED

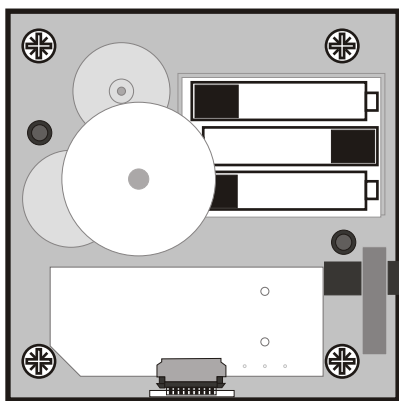

ALKALINE BATTERIES
(1,5 V - AAA)

USE ONLY **ALKALINE** BATTERIES

DO NOT USE RECHARGEABLE BATTERIES

IT IS RECOMMENDED TO REPLACE THE BATTERIES WITHIN 2 YEARS FROM THEIR INSTALLATION



PAY ATTENTION

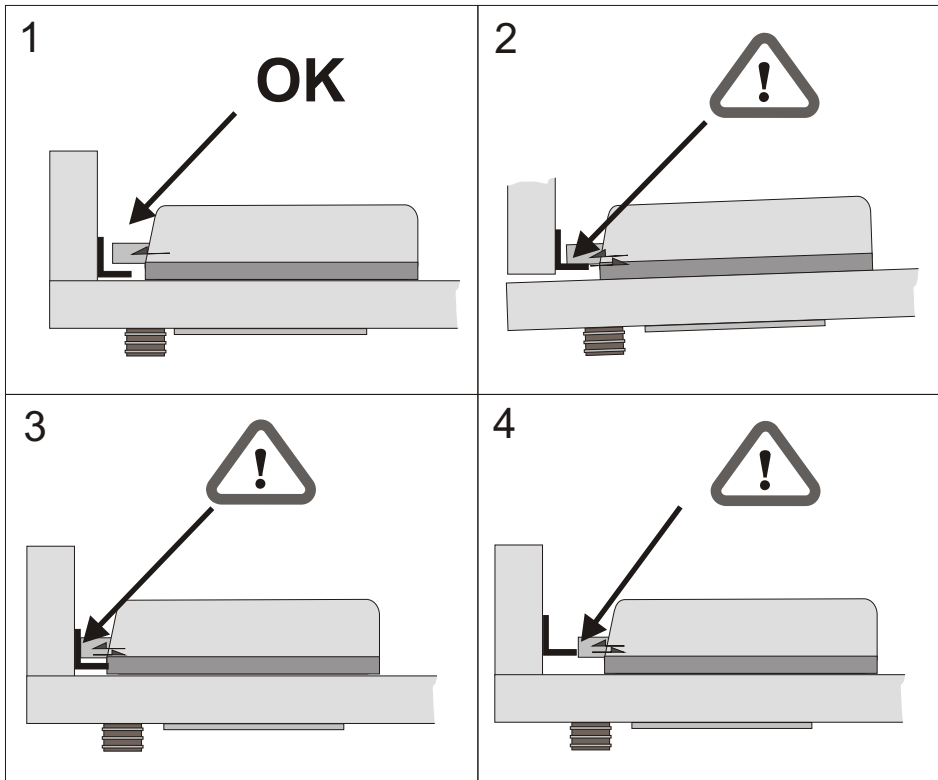

IF DURING THE CLOSING PHASE THE BOLT HITS AGAINST THE STOP-BOLT AND IT DOES NOT CLOSE (SEE FIGURE 3 AND 4) AFTER 3 SECONDS THE BOLT COME BACK IN THE POSITION "OPEN"..

THE REPETITION OF THE PROBLEM COULD DAMAGE THE INTERNAL MECHANISM..



IF THE LOCK CLOSES BUT THE BOLT FORCES HORIZONTALLY AGAINST THE STOP-BOLT (SEE FIGURE 2) THE CONSUMPTION OF BATTERIES DRASTICALLY INCREASES.

TO PREVENT SUCH DISAVANTAGES IT IS ADVISABLE TO KEEP A SECURITY AREA BETWEEN THE BOLT AND THE STOP-BOLT SO THAT THE FUNCTIONING IS PERFECT EVEN WHEN IT HAPPENS A FOULTY ALIGNEMENT OF THE DOOR.

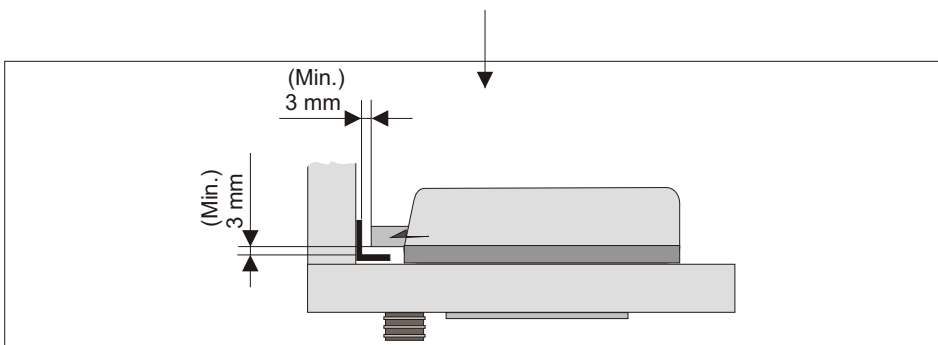

USO OF EXTERNAL POWER SUPPLY (PFAESEL02)

EMERGENCY OPEN

Remove the protection glass and the label as shown in the picture.

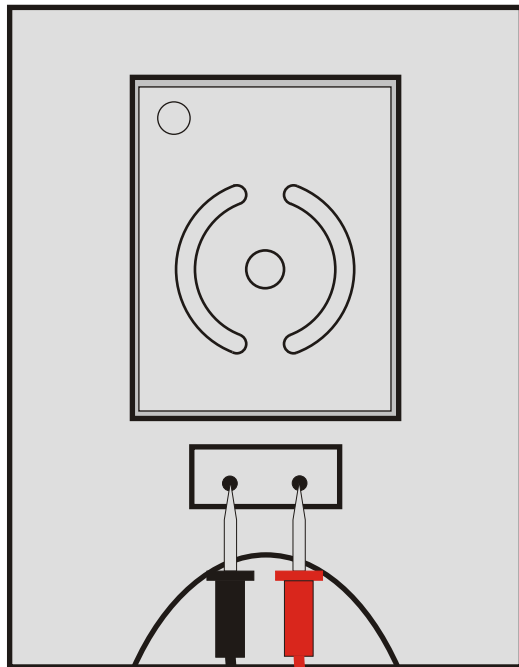
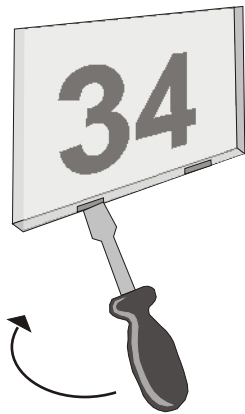

With the external power supply commutator on “ **ON** ” position connect the two metal point in the proper holes paying attention to the polarity.

For opening the lock keep the connected metal points, and lean to the centre of the sensor the PASSEPARTOUT card.

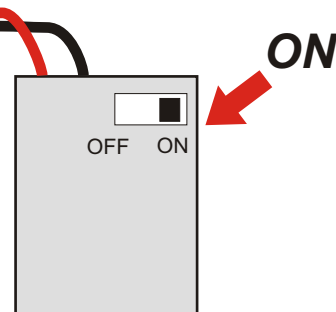

INSTALLATION GUIDE

1

Fig. (1.1)

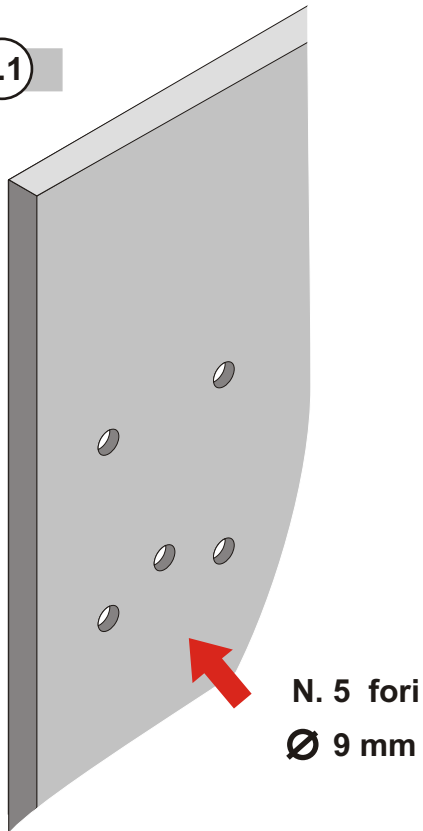

Make on the door n.5 holes of 9 mm diameter.

To determine the horizontal positions of the holes refer to the picture 8.1 and 8.2 and make sure that the bolt of the lock correctly acts while closing and opening

2

Fig. (2.1)

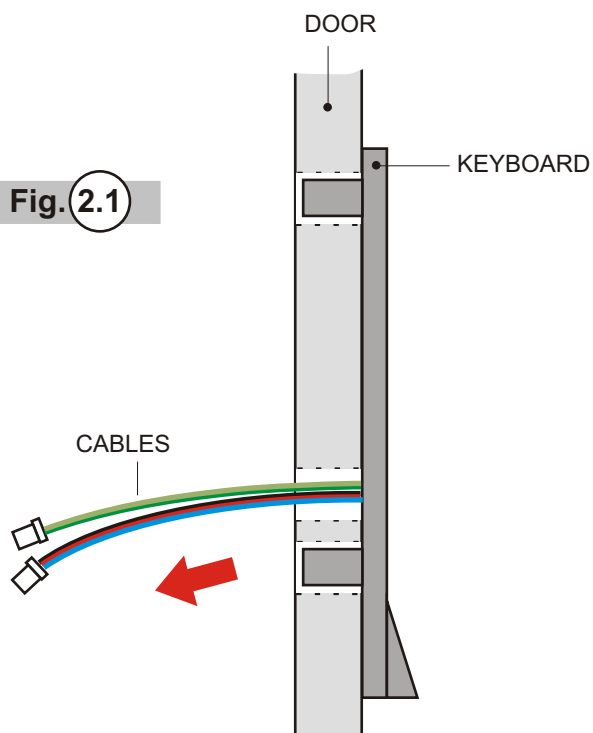

Insert the keyboard on the door by slipping the connector through the central hole.

3

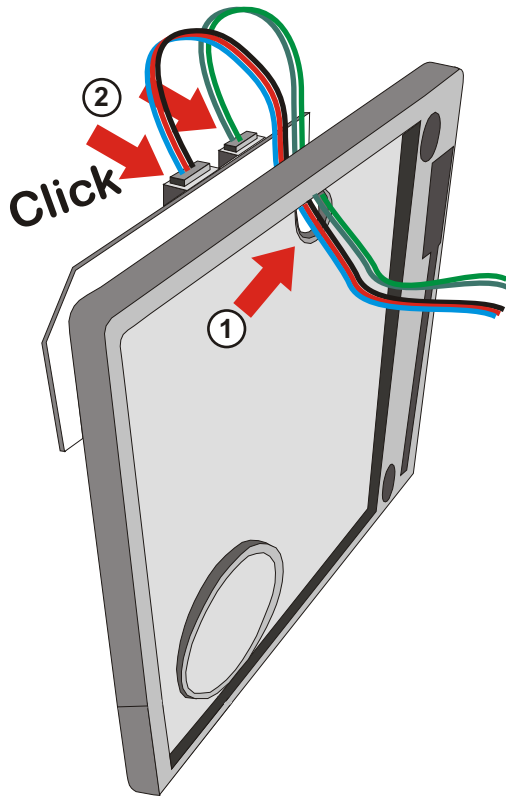

Fig. 3.1

After having removed the cover of the lock slip the cables through the proper hole placed on the back of the lock and insert its in the connectors as shown in the picture.

4

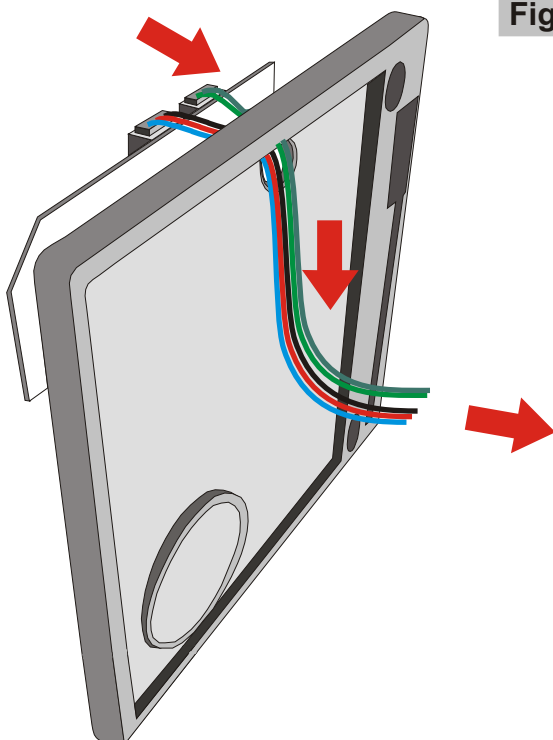
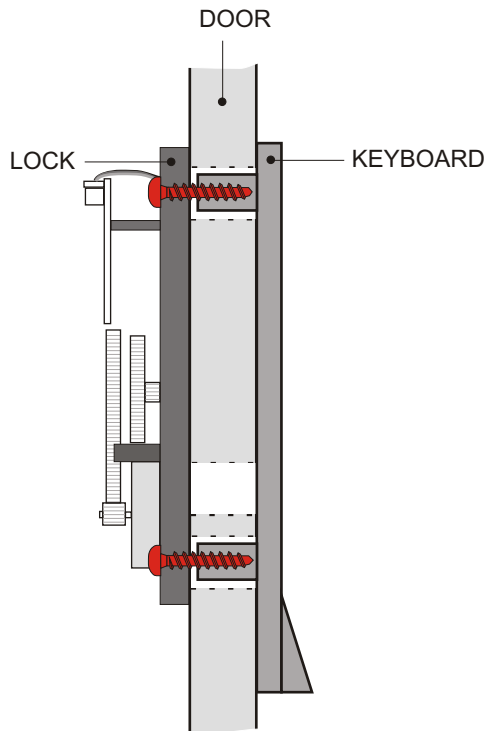

Fig. 4.1

Bend the cables as shown in the picture in such a way to set the wires between the lock and the door.

5

Fig. 5.1



Fix the lock and the keyboard to the door with n.4 screws for plastic materials, cylindric head, 4 mm diameter, 20 mm lenght

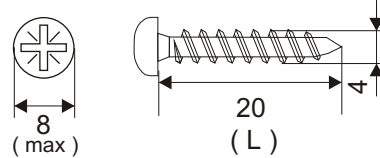
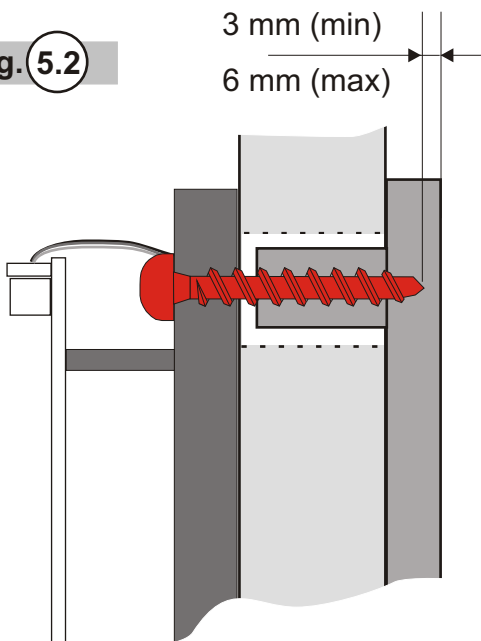

Fig. 5.2



The lenght of the screws (L) may change according to the thickness of the door and the further spacer* used. In any case please make sure, that once fixed, the screws is between 3 and 6 mm from the frontal of the keyboard.

After having fixed the lock to the door, insert the alkaline batteries (AAA) and close it with the cover by the two proper screws.

* for the use of the spacer please see the paragraph n.6

6

USE OF SPACER

Pic. 6.1

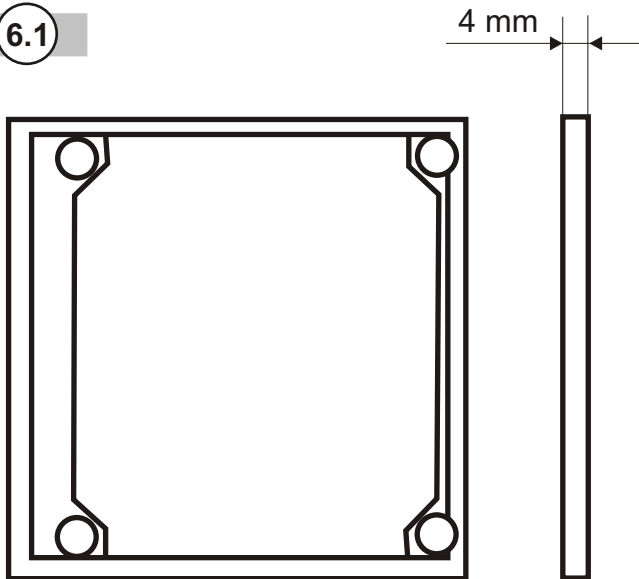

The spacer is an optional accessory to be used when you want to leave the body of the lock from the door.

Pic. 6.2

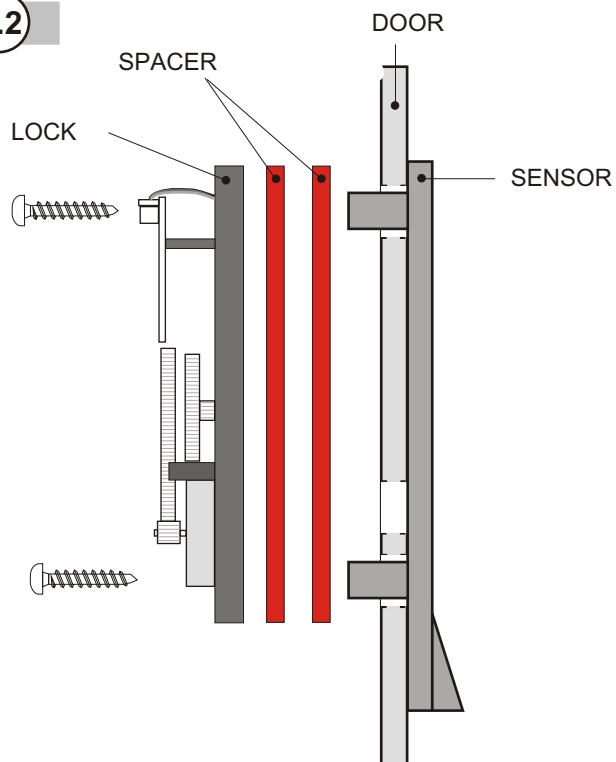

More spacers can be used for the door with reduced thickness.

7

INSTALLATION OF THE NUMBER

Pic. 7.1

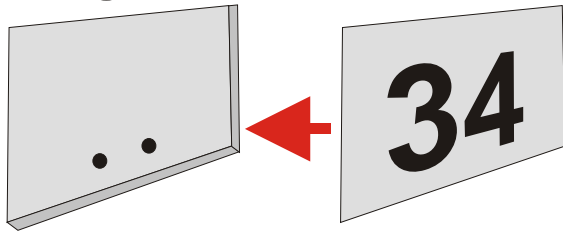

Insert the adhesive label* in the proper space.

* The use of AVERY L 6008 polyester 25,4 x 10 mm labels for laser white and black printers is recommended.

Pic. 7.2

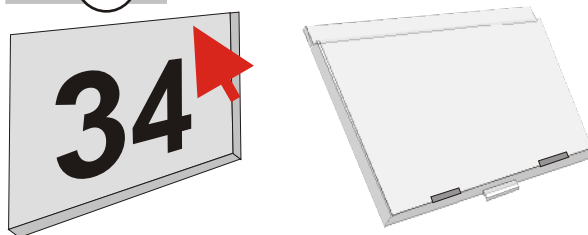

Insert in the slot at the top of the protection glass.
(take care of the exact position)

Pic. 7.3

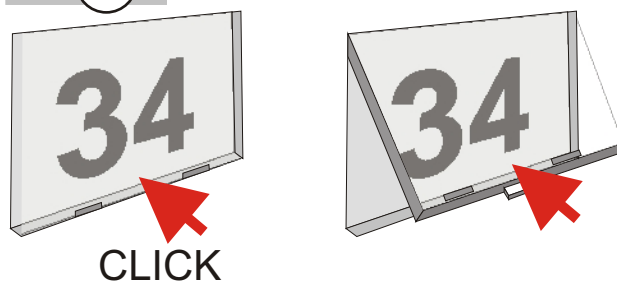

Press where indicated by the arrow in order to hook the glass.

Pic. 7.4



Use a thin screwdriver to remove the glass and lever in the proper grooves.

IMPORTANT : THE PROTECTION GLASS MUST BE INSERTED IN ANY CASE EVEN IF YOU DO NOT WISH TO PUT ANY LABEL ON THE FRONT OF THE KEYBOARD.

8

QUOTE FOR LOCK FIXING

Pic. 8.1

* Model DMI18PG/A/B = 18 mm

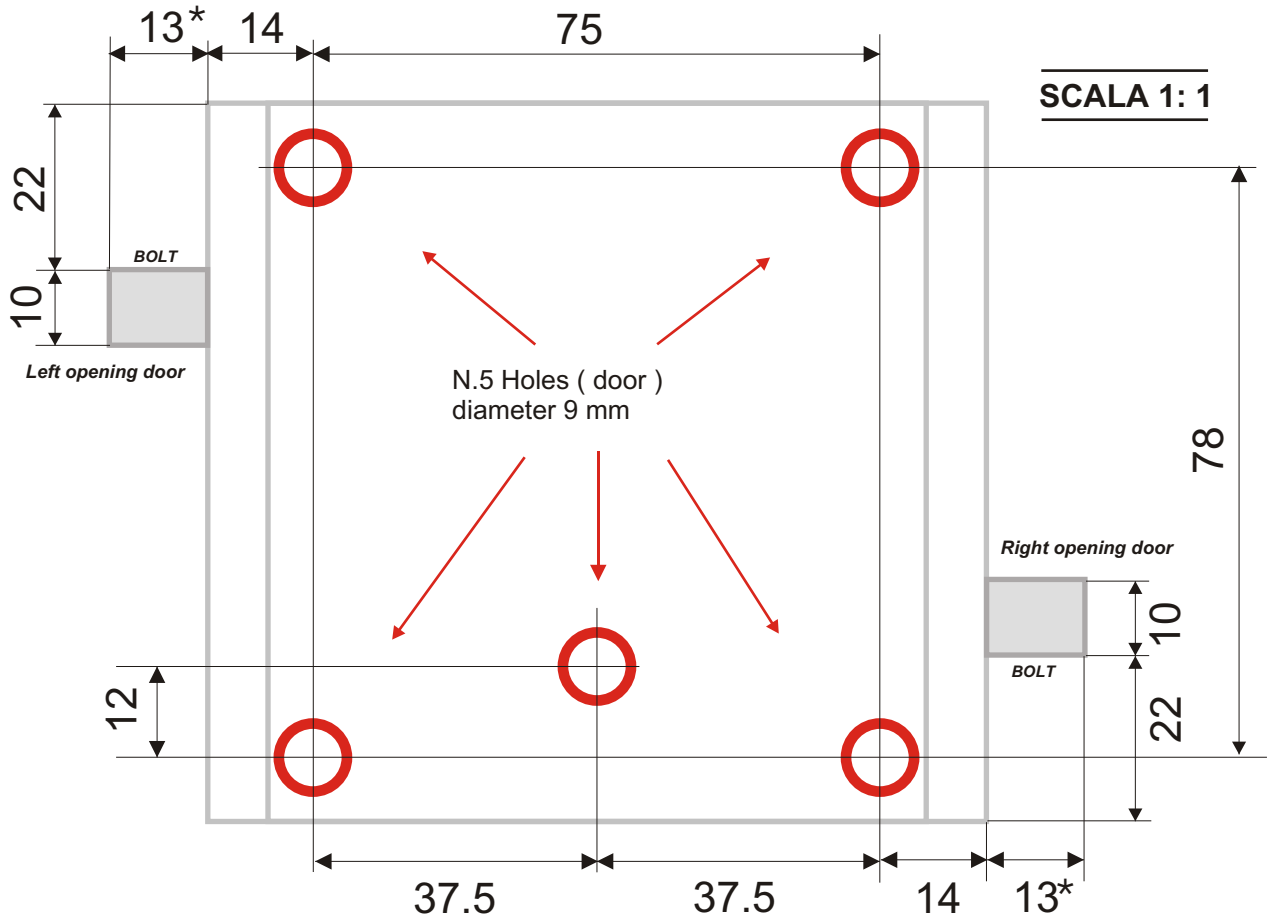

Pic. 8.2

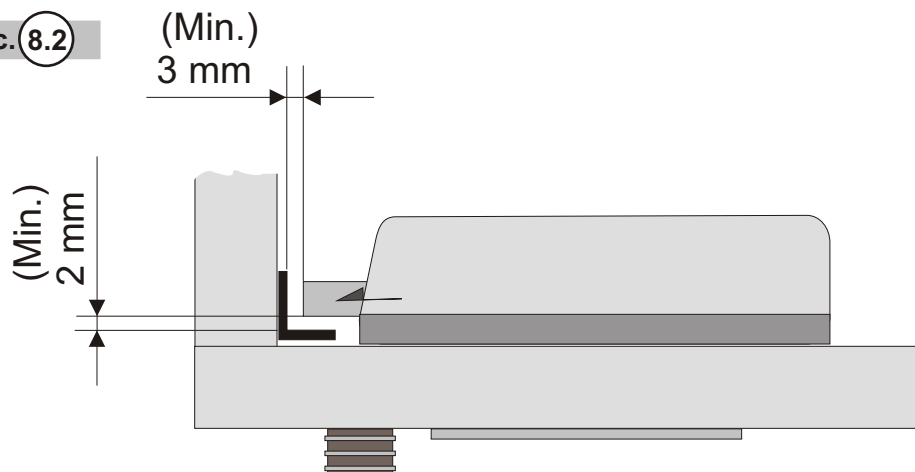

PLEASE NOTE THAT THE NON OBSERVANCE OF THE RULES ABOVE DESCRIBED FOR A CORRECT INSTALLATION WILL AUTOMATICALLY VOID EVERY KIND OF WARRANTY OF THE PRODUCT

9

DIMENSIONS

